

# AtomOne 4K mini 16

The Smallest UHD 1" Global shutter with High Dynamic Range (HDR).



4096 X 2160 (4K Resolution)

**Shutter type:** Global shutter

**Sensor size:** 1"

**Progressive Framerates:** 23.98, 24, 25, 29.97, 30, 47.96, 48, 50, 59.94, 60

**Interlaced Modes:** 50i 59.94i, 60i

**HDR:** HLG, PQ and SLOG3

**Color:** multi matrix support

**Control:** RS 485

**Genlock input**

**SDI output:** 2x HD-SDI output

**One SDI can be downscaled to 3G/HD**

**Microphone:** stereo mic

**Lens:** Wide angle 112° @4,7mm lens (not included)

**Mount:** C-Mount

**Size:** 36mm x 36mm x 74mm

**Weight:** 123g

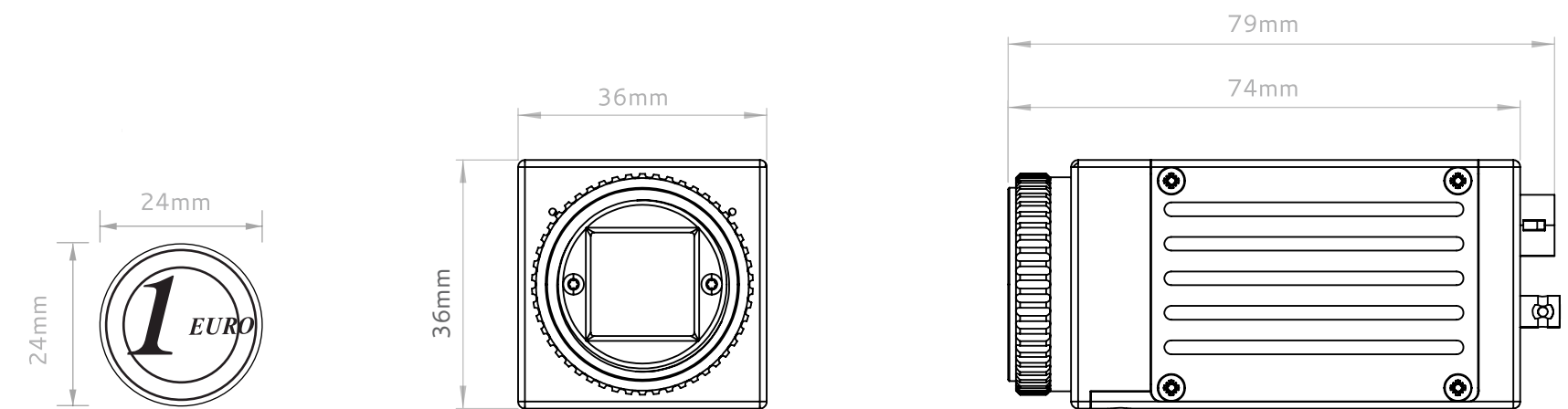

	AtomOne mini	AtomOne mini AIR	AtomOne mini Waterproof	AtomOne	AtomOne SSM-500 C-Mount	AtomOne SSM 500 B4
<b>SHUTTER TYPE</b>	Rolling shutter	Rolling shutter	Rolling shutter	Global shutter	Global shutter	Global shutter
<b>SENSOR SIZE</b>	1/2.5"	1/2.5"	1/2.5"	1/1.23"	2/3"	2/3"
<b>FRAME RATE</b>	23 – 60 fps	23 – 60 fps	23 – 60 fps	23 – 60 fps	50 – 500 fps	50 – 500 fps
<b>PROGRESSIVE FRAMERATES</b>	23.98, 24, 25, 29.97, 30, 50, 59.94, 60	23.98, 24, 25, 29.97, 30, 50, 59.94, 60	23.98, 24, 25, 29.97, 30, 50, 59.94, 60	23.98, 24, 25, 29.97, 30, 50, 59.94, 60	23.98, 24, 25, 29.97, 30, 47.96, 48, 50, 59.94, 60	23.98, 24, 25, 29.97, 30, 47.96, 48, 50, 59.94, 60
<b>INTERLACED MODES</b>	50i, 59.94i, 60i	50i, 59.94i, 60i	50i, 59.94i, 60i	50i, 59.94i, 60i	50i, 59.94i, 60i	50i, 59.94i, 60i
<b>HDR</b>	HLG, PQ and SLOG3	HLG, PQ and SLOG3	HLG, PQ and SLOG3	HLG, PQ and SLOG3	HLG, PQ and SLOG3	HLG, PQ and SLOG3
<b>COLOR</b>	multi matrix support	multi matrix support	multi matrix support	multi matrix support	multi matrix support	multi matrix support
<b>CONTROL</b>	RS 485	RS 485	RS 485	RS 485	RS 485	RS 485
<b>CAMERA MODE</b>	-	-	-	-	SSM mode (4x60p) or Trigger mode	SSM mode (4x60p) or Trigger mode
<b>SDI OUTPUT</b>	1x HD-SDI output	1x HD-SDI output	1x HD-SDI output	2x HD-SDI output	4x HD-SDI output	4x HD-SDI output
<b>GENLOCK INPUT</b>	-	-	-	YES	YES	YES
<b>MOUNT</b>	S Mount	S Mount	S Mount	C Mount	C Mount	B4 Mount
<b>LENS</b>	85° @3.4mm – lens included	85° @3.4mm – lens included	85° @3.4mm – lens included	Wide angle 95° @5mm lens (not included)	Wide angle 112° @3.7mm lens (not included)	-
<b>MICROPHONE</b>	Mono Mic	Mono Mic	Mono Mic	-	-	-
<b>SIZE</b>	30mm x 30mm x 30mm	30mm x 30mm x 18mm	32mm x 32mm x 51mm	32mm x 32mm x 72mm	60mm x 60mm x 189mm	92mm x 80mm x 244mm
<b>WEIGHT</b>	45g	25g	115g	100g	900g	1700g

	AtomOne mini Zoom	AtomOne 4K mini 7	AtomOne 4K mini 11	AtomOne 4K mini 16
<b>SHUTTER TYPE</b>	Rolling shutter	Rolling shutter	Rolling shutter	Global shutter
<b>SENSOR SIZE</b>	1/2.5"	1/2.5"	2/3"	1"
<b>FRAME RATE</b>	-	-	-	-
<b>PROGRESSIVE FRAMERATES</b>	23.98, 24, 25, 29.97, 30, 50, 59.94, 60	23.98, 24, 25, 29.97, 30, 47.96, 48, 50, 59.94, 60	23.98, 24, 25, 29.97, 30, 47.96, 48, 50, 59.94, 60	23.98, 24, 25, 29.97, 30, 47.96, 48, 50, 59.94, 60
<b>INTERLACED MODES</b>	50i 59.94i, 60i	50i 59.94i, 60i	50i 59.94i, 60i	50i 59.94i, 60i
<b>HDR</b>	HLG, PQ and SLOG3	HLG, PQ and SLOG3	HLG, PQ and SLOG3	HLG, PQ and SLOG3
<b>COLOR</b>	multi matrix support	multi matrix support	multi matrix support	multi matrix support
<b>CONTROL</b>	RS 485	RS 485	RS 485	RS 485
<b>CAMERA MODE</b>	-	-	-	-
<b>SDI OUTPUT</b>	1x HD-SDI output	2x HD-SDI output (SDI 1 and SDI 2 can be downscaled to 3G/HD)	2x HD-SDI output (SDI 1 and SDI 2 can be downscaled to 3G/HD)	2x HD-SDI output (SDI 1 and SDI 2 can be downscaled to 3G/HD)
<b>GENLOCK INPUT</b>	-	YES	YES	YES
<b>MOUNT</b>	-	S-Mount or C-Mount (not included)	C-Mount	C Mount
<b>LENS</b>	F1.6 – 2.9mm(130°) – 9mm(66°)	85° @3.4mm – lens included	Wide angle 76° @6mm lens (not included)	Wide angle 112° @4.7mm lens (not included)
<b>MICROPHONE</b>	Mono Mic	Stereo mic	Stereo mic	Stereo mic
<b>SIZE</b>	60mm x 60mm x 80mm	36mm x 36mm x 74mm	36mm x 36mm x 74mm	36mm x 36mm x 74mm
<b>WEIGHT</b>	267g	122g	123g	123g